

## Chimera FET (V3 GB) Installation

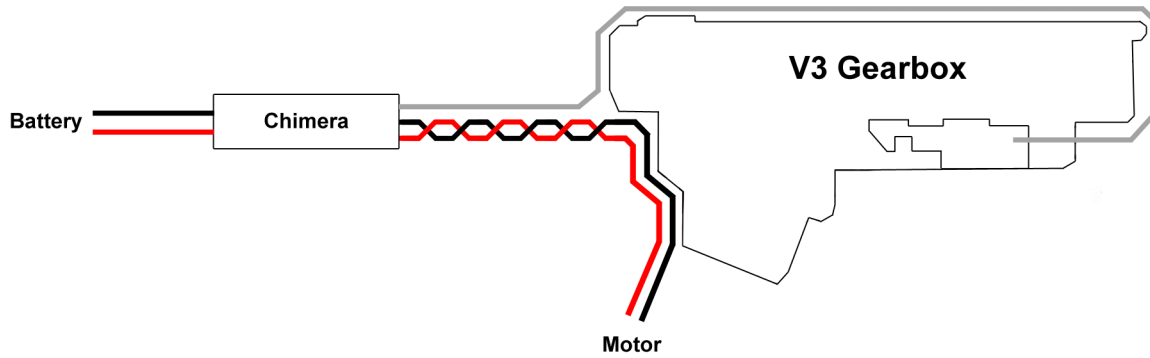

### Selector Plate Modification

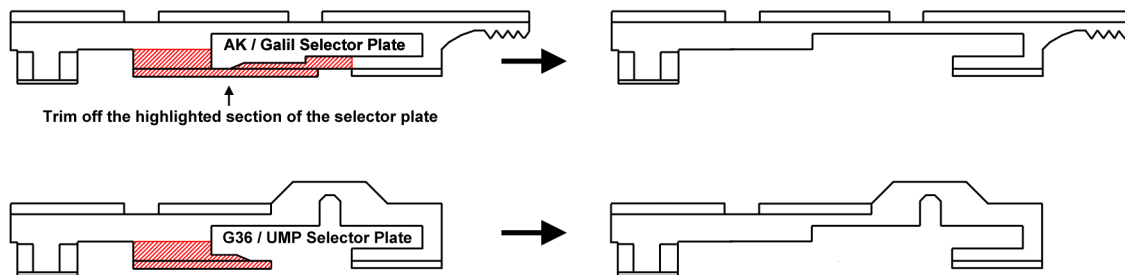

### Tappet Plate Modification

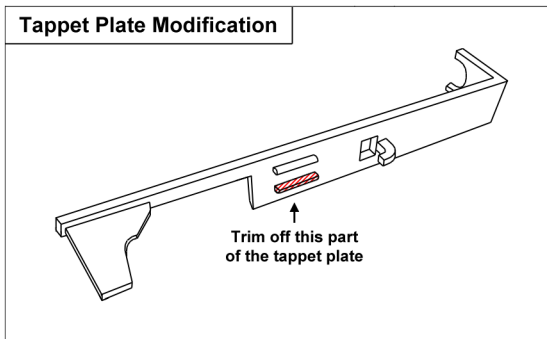

### Trigger Board Assembly

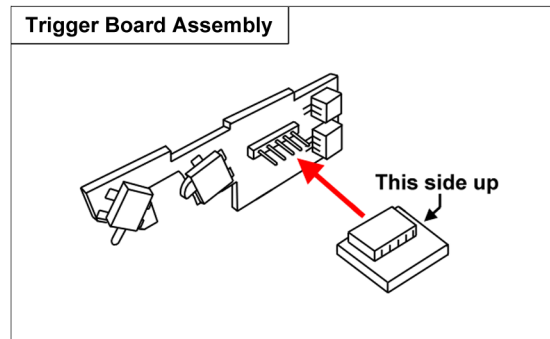

### INSTALLATION:

- 1) Modify the selector plate and tappet plate as shown in the above diagrams and put them back in the gearbox.
- 2) Snap apart and assemble the two parts of the trigger board as shown above.
- 3) Replace the stock trigger assembly with the Chimera trigger board.  
**\*\* DO NOT push the selector switch on the trigger board in the wrong direction! This will destroy the switch.**
- 4) Cut the battery and motor wires to the desired length and strip off at least 4mm of insulation from the wire ends.
- 5) Twist the motor wires as shown above. This suppresses motor noise and ensures the Chimera functions properly.
- 6) Insert the wires as far as possible into the Chimera's wire terminals and firmly tighten the clamping screws.  
**\*\* Note the polarity markings on the underside of the Chimera. Improper connections will void the warranty.**
- 7) Connect the trigger board to the Chimera using the two data cables. Tie up excess length to reduce clutter.  
**\*\* Never pull out the data cables by tugging the wires. Always grip the side tabs on the connectors.**

# Programming Mode

To enter programming mode, connect the battery while holding the trigger down. The motor will buzz **4 times** if successful.

## Main Category

1	LiPoly Monitoring
2	Fire Mode
3	RoF Control
4	Precocking
5	Motor Brake
6	Fire Mode
7	RoF Control
8	Precocking
9	Motor Brake

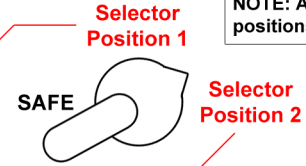

NOTE: AK selector positions are reversed!

After input, wait 3s until motor buzzes **2 times**

After input, wait 3s until motor buzzes **4 times**  
*Setting saved, battery can be disconnected if done*

## Subcategory

<p><b>LiPoly Monitoring</b></p> <table border="1"> <tr><td>1</td><td>Disabled</td></tr> <tr><td>2</td><td>2-cell LiPoly or 3-cell LiFePO</td></tr> <tr><td>3</td><td>3-cell Lipoly or 4-cell LiFePO</td></tr> <tr><td>4</td><td>4-cell Lipoly</td></tr> </table>	1	Disabled	2	2-cell LiPoly or 3-cell LiFePO	3	3-cell Lipoly or 4-cell LiFePO	4	4-cell Lipoly	<p><b>Fire Mode</b> Selector Postion 1 or 2</p> <table border="1"> <tr><td>1</td><td>Semi</td></tr> <tr><td>2</td><td>Auto</td></tr> <tr><td>3</td><td>2rnd Burst</td></tr> <tr><td>4</td><td>3rnd Burst</td></tr> <tr><td>5</td><td>3rnd Burst No Interrupt</td></tr> <tr><td>6</td><td>Burst-Auto Hybrid</td></tr> </table>	1	Semi	2	Auto	3	2rnd Burst	4	3rnd Burst	5	3rnd Burst No Interrupt	6	Burst-Auto Hybrid	<p><b>RoF Control</b> Selector Postion 1 or 2</p> <table border="1"> <tr><td>1</td><td>Disabled</td></tr> <tr><td>2</td><td>10ms delay between shots</td></tr> <tr><td>3</td><td>20ms</td></tr> <tr><td>4</td><td>30ms</td></tr> <tr><td>5</td><td>40ms</td></tr> <tr><td>6</td><td>50ms</td></tr> <tr><td>7</td><td>60ms</td></tr> <tr><td>8</td><td>70ms</td></tr> </table>	1	Disabled	2	10ms delay between shots	3	20ms	4	30ms	5	40ms	6	50ms	7	60ms	8	70ms	<p><b>Precocking</b> Selector Postion 1 or 2</p> <table border="1"> <tr><td>1</td><td>Disabled</td></tr> <tr><td>2</td><td>10ms precock after shots</td></tr> <tr><td>3</td><td>20ms</td></tr> <tr><td>4</td><td>30ms</td></tr> <tr><td>5</td><td>40ms</td></tr> <tr><td>6</td><td>50ms</td></tr> <tr><td>7</td><td>60ms</td></tr> <tr><td>8</td><td>70ms</td></tr> </table>	1	Disabled	2	10ms precock after shots	3	20ms	4	30ms	5	40ms	6	50ms	7	60ms	8	70ms
1	Disabled																																																						
2	2-cell LiPoly or 3-cell LiFePO																																																						
3	3-cell Lipoly or 4-cell LiFePO																																																						
4	4-cell Lipoly																																																						
1	Semi																																																						
2	Auto																																																						
3	2rnd Burst																																																						
4	3rnd Burst																																																						
5	3rnd Burst No Interrupt																																																						
6	Burst-Auto Hybrid																																																						
1	Disabled																																																						
2	10ms delay between shots																																																						
3	20ms																																																						
4	30ms																																																						
5	40ms																																																						
6	50ms																																																						
7	60ms																																																						
8	70ms																																																						
1	Disabled																																																						
2	10ms precock after shots																																																						
3	20ms																																																						
4	30ms																																																						
5	40ms																																																						
6	50ms																																																						
7	60ms																																																						
8	70ms																																																						
<p>Pressing the trigger more times then the number of options will set the trigger press counter back to '1' and emit a longer motor buzz.</p>																																																							
			<p><b>Motor Brake</b> Selector Postion 1 or 2</p> <table border="1"> <tr><td>1</td><td>Disabled</td></tr> <tr><td>2</td><td>Light Braking</td></tr> <tr><td>3</td><td>Medium Braking</td></tr> <tr><td>4</td><td>Max Braking</td></tr> </table>	1	Disabled	2	Light Braking	3	Medium Braking	4	Max Braking																																												
1	Disabled																																																						
2	Light Braking																																																						
3	Medium Braking																																																						
4	Max Braking																																																						

### PROGRAMMING EXAMPLE:

#### Setting fire selector to SAFE - 2 BURST - 3 BURST

- 1) Connect battery while holding down the trigger.
- 2) Press trigger **2 times** to select "Selector Position 1 - Fire Mode". Wait 3s until the motor buzzes 2 times.
- 3) Press trigger **3 times** to select "2rnd Burst". Wait 3s until the motor buzzes 4 times.
- 4) Press trigger **6 times** to select "Selector Position 2 - Fire Mode". Wait 3s until the motor buzzes 2 times.
- 5) Press trigger **4 times** to select "3rnd Burst". Wait 3s until the motor buzzes 4 times.
- 6) Disconnect the battery to exit programming mode.

### FACTORY RESET:

To reset all settings back to factory defaults, enter programming mode but continue holding down the trigger for 5 seconds (do not release the trigger or the battery will need to be reconnected). The motor will emit a very long buzz upon a successful reset and continue on to programming mode.

#### Factory default settings

Fire mode configuration = SAFE-SEMI-AUTO  
 Lipoly monitoring, RoF control, precocking, motor brake = DISABLED

---

## Controller Functions

---

### MOSFET Trigger

High battery voltages tend to cause an AEG's mechanical trigger switch to wear down over time due to electrical arcing. As this damage progresses the contacts on the switch begin to oxidize, reducing the conductive surface area of the contacts. This reduces the AEG's RoF and causes the switch to get hotter as the damage worsens. Eventually the mechanical switch will become distorted by the increasing heat and become unusable.

The Chimera controller routes 99% of the motor current through the controller's MOSFETs, which are basically a "solid state" switch with no mechanical parts, thus completely eliminating electrical arcs. **THIS FUNCTION IS ALWAYS ACTIVE.**

---

### Cycle Complete

Most AEGs are designed to have the motor power cut off as soon as the trigger is released. But on full auto this cause incomplete cycles since the piston can stop at any position when the trigger is released. This can cause the gearbox to seize since the motor won't be able to have a "running start".

The Chimera prevents this problem by always completing the current cycle no matter when the trigger is released. This guarantees the piston will always return to battery (unless precocking is enabled). Motor braking should be enabled if the motor has severe overspin. **THIS FUNCTION IS ALWAYS ACTIVE.**

---

### Motor Brake

On high speed setups the motor won't be able to stop immediately when the power is cut off, instead it continues spinning for a few more rotations due to inertia. This "overspin" can result in the piston stopping at a partially compressed state, creating unnecessary strain on the gearbox internals and possibly causing the gearbox to seize since the motor won't be able to have a "running start".

The Chimera's motor braking function forces the motor to come to an immediate stop by use of "dynamic braking". Sparks can be seen from the bottom of the motor when the brake kicks in. This is normal and lets you know that the brakes are functioning properly.

**WARNING: BRAKING IS TOUGH ON THE MOTOR BRUSHES AND WEARS IT DOWN FASTER. DO NOT USE A HIGHER BRAKE SETTING THAN NECESSARY.**

---

### Burst Fire Modes

Allows the user to assign various different forms of burst fire to any of the fire selector positions. The burst fire will terminate if the trigger is released before the burst is completed, except for the "no interrupt" burst which will continue firing the remaining rounds in the burst. Burst-auto hybrid mode fires a burst if the trigger is quickly tapped and full auto if the trigger remains held down.

---

### Rate of Fire (RoF) Control

The Chimera provides the most efficient form of RoF control for AEGs by adding a delay between shots while cycling each shot all full speed. Compared to most RoF controllers that use PWM, the Chimera's "delay-based" RoF control is more realistic, wastes less energy, does not overheat the controller, never jams on the lowest RoF setting, and most importantly works on all setups.

---

### Precocking Control

The precocking function purposely "overspins" the motor for a set amount of time so the piston stops in a compressed position. This allows the next shot to be nearly instantaneous since the piston is now "precocked". This can be useful in AEGs with a low cycle rate or sniper builds.

**WARNING: PRECOCKING CAN JAM GEARBOXES THAT DO NOT HAVE ENOUGH TORQUE TO OVERCOME A PRECOCKED PISTON. NOT RECOMMENDED FOR LOW-TORQUE OR HIGH-SPEED SETUPS. ALSO DRAINS BATTERIES FASTER DUE TO HIGHER STARTUP CURRENT SURGES.**

---

### Lipoly Monitoring

Continuously monitors a lipoly battery to make sure its voltage level doesn't drop below the "point of no return" threshold (typically 3.2V per cell). Will stop the motor and emit a low voltage warning when this threshold is reached.

**WARNING: MAKE SURE TO BALANCE YOUR LIPOLY BATTERIES OCCASSIONALLY. THIS FUNCTION IS NOT EFFECTIVE AT PROTECTING UNBALANCED LIPOLYS SINCE IT CAN'T READ THE VOLTAGE OF EACH INDIVIDUAL CELL.**

## Troubleshooting

Problem	Checklist
Motor stops firing and begins to buzz repeatedly.	<ul style="list-style-type: none"><li>- 1 buzz every 1s = Battery or lipoly voltage too low. Recharge your batteries.</li><li>- 2 quick buzzes every 1s = Short circuit detected. Check wirings and if gearbox is seized.</li><li>- 3 quick buzzes every 1s = Abnormal temperature readings. Reshim or increase gearbox torque.</li></ul>
No response when trigger is pressed.	<ul style="list-style-type: none"><li>- Make sure the battery is sufficiently charged.</li><li>- Check the battery, motor, data and screw terminal connections.</li><li>- Check for any shorts or tears in the wirings.</li></ul>
Motor braking not stopping piston at rest position.	<ul style="list-style-type: none"><li>- Increase braking power (but will increase wear on the motor brushes).</li><li>- Clean the motor shaft and replace the motor brushes if worn down.</li></ul>
AEG only fires full auto and continues firing for 0.5s after trigger is released.	<ul style="list-style-type: none"><li>- The selector plate needs to be modified so that it never touches the cutoff lever.</li><li>- The stock cutoff lever spring must be replaced with the extended spring.</li></ul>
Selector unable to switch between different firing modes.	<ul style="list-style-type: none"><li>- The selector plate should properly press and release the external switch on the trigger board.</li><li>- The circular plate behind the AEG's fire select switch might be misaligned or loose.</li></ul>
Precock causing double firing.	<ul style="list-style-type: none"><li>- Precock time too high for your setup, lower the setting in programming mode.</li></ul>

## Limited Warranty

BlackTalon Concepts warrants for 12 months after purchase that its products will be free from defects in material and workmanship. BTC will repair or replace any product which is found to be defective under normal use and service, without charge. BTC's obligation to repair or replace shall be the purchaser's sole and exclusive remedy under this warranty.